



SQM5..., gear train side with drive shaft no. 7

SQM5..., rear, version without second drive shaft end

SQM5..., rear, version with 2 drive shaft ends

## Actuators for Air and Gas Dampers

## SQM5...

with electronic modules

- Reversible electromotive actuators up to 40 Nm
- Running times from 10 to 90 seconds
- With 1 or 2 drive shaft ends; drive shafts can be exchanged or available as separate items
- Can be equipped with electronic modules for control and position feedback signal via steady signals
- Internal and external position indication
- Drive shaft and cam shaft can be separately disengaged
- Choice of UL-listed types for use in the U.S. and Canada
- Supplementary Data Sheets, refer to N7921 and N7922

The SQM5... and this Data Sheet are intended for use by OEMs which integrate the SQM5... in their products!

### Use

The SQM5... actuators are used to drive air and gas dampers of oil and gas burners of medium to large capacity.

They are used primarily for load-dependent control of the amounts of gas, oil and combustion air:

- In connection with 3-position or modulating controllers (e.g. 4...20 mA), or
- Directly by burner controls

## Warning notes

---



To avoid injury to persons, damage to property or the environment, the following warning notes must be observed!

**Only qualified staff may open, interfere with or modify the actuators!**

- All activities (mounting, installation and service work, etc.) must be performed by qualified staff
- Before making any wiring changes in the connection area, completely isolate the plant from mains supply (all-polar disconnection). Ensure that the plant cannot be inadvertently switched on again and that it is indeed dead. If not observed, there is a risk of electric shock hazard
- Ensure protection against electric shock hazard by providing adequate protection for the connection terminals
- Protection against electric shock hazard is ensured by folding upwards cover of control unit (made of plastic), allowing safe setting of the cams when mains voltage is present
- Each time work has been carried out (mounting, installation, service work, etc.), check to ensure that wiring is in an orderly state
- Fall or shock can adversely affect the safety functions. Such actuators must not be put into operation even if they do not exhibit any damage

## Mounting notes

---

- Ensure that the relevant national safety regulations are complied with

## Standards and certificates

---



Conformity to EEC directives  
- Electromagnetic compatibility EMC (immunity)  
- Low-voltage directive

2004/108/EC  
2006/95/EC





ISO 9001: 2000  
Cert. 00739



ISO 14001: 2004  
Cert. 38233



For use in the U.S. / Canada, the actuators carry type suffix «R» (see example) and are  UL- and  CSA-listed.

Example: SQM50.480R1

## Disposal notes

---



The actuator contains electrical and electronic components and must not be disposed of together with domestic waste.  
Local and currently valid legislation must be observed.

## Mechanical design

- Housing
- Housing sections made of die-cast aluminium
  - Covers made of impact-proof and heat-resistant plastic
- Drive motor
- Reversible and locking-proof synchronous motor
- Couplings
- **Driven** shaft and cam shaft can be adjusted via 2 separately couplers, independent of the gear train
  - Shaft can be disengaged from gear train and motor **via manual operation of a coupler (pressure pin «K»**, refer to «Technical data»).
  - Automatic reengagement
  - **Pressure pin «K...»**

- Disengagement of gear train / cam shaft by pressing pin «K1»

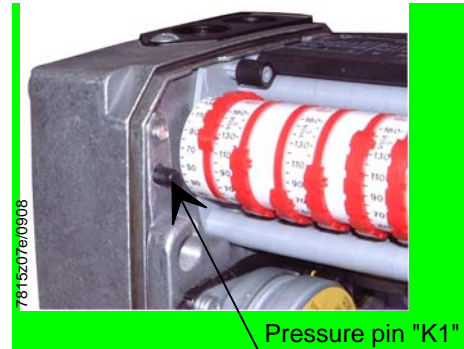

- Disengagement of cam / gear train by pressing pin «K2»

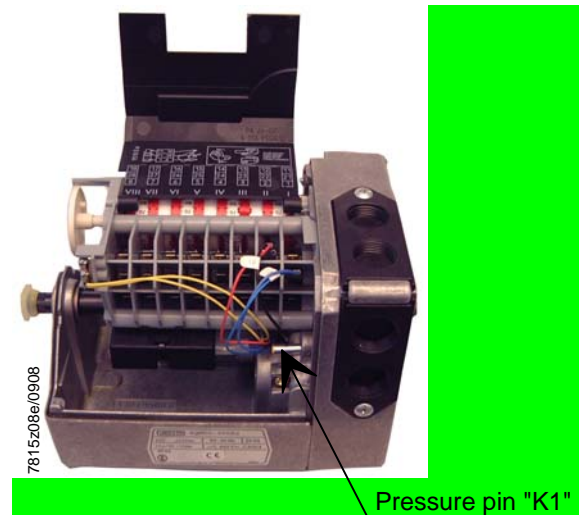

- Cam shaft drive
- Backlash-free gearing
- Adjustment of switching points
- With rotating cams
  - Scales beside the cams indicate the angle of the switching point
- Position indication
- Internally:
    - Scale at the end of the drive shaft
    - Black scale for counterclockwise rotation, single arrow on the cam
    - Red scale for clockwise rotation, double arrow on the cam
  - Externally:
    - Scale in viewing window

## Mechanical design (cont'd)

---

- |                        |   |
|------------------------|---|
| Electrical connections | <ul style="list-style-type: none"><li>• Blade terminal on micro switch</li><li>• Screw terminals for «N» and «PE»</li><li>• Subassembly and fixing of wiring by means of removable Pg plastic insert possible</li><li>• Easy introduction of cables through large openings in the housing</li><li>• Fixing of Pg insert with all cables by means of a screw</li></ul> |
| Gear train             | <ul style="list-style-type: none"><li>• Maintenance-free gearwheels and bearings</li></ul>  |
| Drive shaft            | <ul style="list-style-type: none"><li>• Secured with a removable circlip</li><li>• Easily exchangeable</li><li>• With corresponding shaft both sides transmission possible</li></ul>  |
| Actuator fixing        | <ul style="list-style-type: none"><li>• Fixing holes on the front of the housing and at the bottom</li><li>• Front fixing also possible from inside the housing</li><li>• Variable mounting height through the use of an extra adapter</li></ul>  |

**Type summary** (other types are available on request)

When ordering, please give type reference according to **following tables**.

Accessories are to be ordered separately.

Actuators with premounted accessories are only available on request.

**AC 220 V -15 %...AC 240 V+10 %, 50...60 Hz ±6 %**

Standard types! (other versions on request)	Torque and holding torque  3)	Running time at 50 Hz for angular rotation 1)		Auxiliary switches incl. 2 end switches	Type of shaft	Electronic module (integrated ex works) 5)	Potentiometer  (integrated ex works) 6)
		90°	130°				
Type reference	max. Nm 2)						
SQM50.260A2G4	10	10 s	14 s	4	---	56.41A27	12.33
SQM50.341A2	10	15 s	22 s	4	58.1	---	---
SQM50.341A2G3	10	15 s	22 s	4	58.1	56.41A27	12.30
SQM50.341A2K3	10	15 s	22 s	4	58.1	56.43A27	12.30
SQM50.381A2	10	15 s	22 s	8	58.1	---	---
SQM50.381A2G3	10	15 s	22 s	8	58.1	56.41A27	12.30
SQM50.441A2	10	30 s	43 s	4	58.1	---	---
SQM50.441A2G3	10	30 s	43 s	4	58.1	56.41A27	12.30
SQM50.480A2	15	30 s	43 s	8	---	---	---
SQM50.480A2Z3	15	30 s	43 s	8	---	56.9A27	12.30
SQM50.481A2	10	30 s	43 s	8	58.1	---	---
SQM50.481A2G3	10	30 s	43 s	8	58.1	56.41A27	12.30
SQM50.481A2Z3	10	30 s	43 s	8	58.1	56.9A27	12.30
SQM50.482A2	15	30 s	43 s	8	58.2	---	---
SQM50.482A2Z3	15	30 s	43 s	8	58.2	56.9A27	12.30
SQM50.483A2Z3	15	30 s	43 s	8	58.3	56.9A27	12.30
SQM50.681A2	10	60 s	87 s	8	58.1	---	---
SQM53.482A2	20	30 s	43 s	8	58.2	---	---
SQM53.482A2Z3	20	30 s	43 s	8	58.2	56.9A27	12.30
SQM53.489A2	25	30 s	43 s	8	58.9	---	---
SQM54.480A2	25	30 s	43 s	8	---	---	---
SQM54.482A2	20	30 s	43 s	8	58.2	---	---
SQM54.482A2	20	30 s	43 s	8	58.2	---	---
SQM54.580A2Z3	25	45 s	65 s	8	---	56.9A27	12.30
SQM56.680A2	40	60 s	87 s	8	---	---	---
SQM56.684A2G4	30	60 s	87 s	8	58.4	56.41A27	12.33
SQM56.684A2Z3	30	60 s	87 s	8	58.4	56.9A27	12.30
SQM56.687A2	40	60 s	87 s	8	58.7	---	---
SQM56.687A2G3	40	60 s	87 s	8	58.7	56.41A27	12.30
SQM56.687A2Z3	40	60 s	87 s	8	58.7	56.9A27	12.30

**Type summary** (other types are available on request) [cont'd]

**AC 100 V -15 %...AC 110 V+10 %, 50...60 Hz ±6 %**

Standard types! (other versions on request)	Torque and holding torque  3)	Running time at 50 Hz for angular rotation 1)		Auxiliary switches incl. 2 end switches	Type of shaft	Electronic module (integrated ex works) 5)	Potentiometer  (integrated ex works) 6)
		90°	130°				
<del>SQM50.454A1</del>	<del>15</del>	<del>30 s</del>	<del>43 s</del>	<del>5</del>	<del>58.4</del>	<del>---</del>	<del>---</del>
SQM50.480A1	15	30 s	43 s	8	---	---	
SQM50.480A1Z3	15	30 s	43 s	8	---	56.9A17	
SQM50.483A1Z3	15	30 s	43 s	8	58.3	56.9A17	12.30
SQM53.480A1	25	30 s	43 s	8	---	---	
SQM53.482A1Z3	20	30 s	43 s	8	58.2	56.9A17	12.30
SQM56.687A1	40	60 s	87 s	8	58.7	---	---
SQM56.687A1Z3	40	60 s	87 s	8	58.7	56.9A17	12.30

**AC 24 V -15 / +10 %, 50...60 Hz ±6 %**

Standard types! (other versions on request)	Torque and holding torque  3)	Running time at 50 Hz for angular rotation 1)		Auxiliary switches incl. 2 end switches	Type of shaft	Electronic module (integrated ex works) 5)	Potentiometer  (integrated ex works) 6)
		90°	130°				
SQM50.380A8	10	15 s	22 s	8	---	---	
SQM50.443A8	15	30 s	43 s	4	58.3	---	
SQM50.444A8	15	30 s	43 s	4	58.4	---	
SQM50.444A8Z3	15	30 s	43 s	4	58.4	56.9A87	12.30
SQM50.454A8	15	30 s	43 s	5	58.4	---	
SQM50.483A8	15	30 s	43 s	8	58.3	---	
SQM50.483A8Z3	15	30 s	43 s	8	58.3	56.9A87	12.30

- 1) At 60 Hz frequency, running times are about 17 % shorter
- 2) Based on 250,000 position changes
- 3) Refer to «Drive shafts» and «Torques», depending on voltage
- 4) Drive shaft to be ordered separately
- 5) For details, refer to Data Sheet N7922
- 6) For details, refer to Data Sheet N7921

## Accessories

### Potentiometers ASZ...

- ASZxx.3x refer to Data Sheet N7921
- ASZxx.7xx refer to Mounting Instruction M7921 (4 319 9604 0)
- ASZxx.8xx refer to Mounting Instruction M7806 / M7808 / M7812 (4 319 2263 0)
- ASZxx.9xx refer to Mounting Instruction M7806 / M7808 / M7812 (4 319 2263 0)

### Mounting kit

**ASK33.9**

- For fitting the SQM5... to butterfly valves VKF41... , always with drive shaft AGA58.1
- Refer to Mounting Instruction M7815.4 (4 319 9535 0)



### Pg insert

**AGA55.2**

- Inclusive sealing and screw, for SQM5...

### Kit for shaft seal

**AGA55.5**

- For sealing the shaft feedthrough and therewith for perfecting the degree of protection
- On both sides shaft seals for actuator SQM5...
- Packed as kit together with O-rings inclusive mounting screws
- Refer to Mounting Instruction M7815.5 (74 319 0577 0)

### Spacer

**AGA57.1**

- Adapter for SQM10... / SQM20...
- Refer to Mounting Instructions M7815.1 (4 319 9529 0)

### Adapter for actuator ME8

**AGA57.2**

- Refer to Mounting Instruction M7815.2 (4 319 9536 0)

### Adapter for Honeywell Mod. III actuator

**AGA57.3**

- Refer to Mounting Instruction M7815.2 (4 319 9536 0)

### Electronic modules

**AGA56...**

- For control of the actuator
- **Modular installable**, complete with mounting frame and fixing screws
- Refer for **AGA56.1...** Data Sheet N7922 and Mounting Instruction M7922.3 (4 319 9602 0)
- Refer for **AGA56.4...** Data Sheet N7922 and Mounting Instruction M7922.2 (4 319 9542 0)
- Refer for **AGA56.9...** Data Sheet N7922 and Mounting Instruction M7922.1 (4 319 9532 0)

## Drive shafts:

Type of drive shaft	Max. torque	Type no.	Order no.
<b>10 mm dia., single-sided</b> , Woodruff key to DIN 6888, equivalent to drive shaft of SQM10...	10 Nm	1	<b>AGA58.1</b>
<b>10 mm dia., single-sided</b> , Woodruff key to DIN 6888, equivalent to drive shaft of SQM10..., packs of 10 pieces	10 Nm	1	<b>AGA58.1(10)</b>
<b>12 mm dia., single-sided</b> , Woodruff key to DIN 6888, equivalent to drive shaft of SQM20...	20 Nm	2	<b>AGA58.2</b>
<b>9 mm square, double-sided</b> , equivalent to drive shaft of ME8	25 Nm	3	<b>AGA58.3</b>
<b>9.5 mm square, double-sided</b> , equivalent to drive shaft of Honeywell Mod. III	30 Nm	4	<b>AGA58.4</b>
<b>9.5 mm square, double-sided</b> , equivalent to drive shaft of Honeywell Mod. III, packs of 10 pieces	30 Nm	4	<b>AGA58.4(10)</b>
<b>10 mm dia. gear train side, 9.5" square rear</b> , Woodruff key to DIN 6888, equivalent to drive shaft of Honeywell Mod. SQM10...	<b>10</b>	<b>6</b>	<b>AGA58.6</b>
<b>14 mm dia., single-sided with parallel key</b> to DIN 6885, mandatory with SQM56...	40 Nm	7	<b>AGA58.7</b>
<b>14 mm dia., single-sided with parallel key</b> to DIN 6885, mandatory with SQM56..., packs of 10 pieces	40 Nm	7	<b>AGA58.7(10)</b>
<b>12 mm square, single-sided</b>	30 Nm	9	<b>AGA58.9</b>

Refer to Mounting Instruction M7815.3 (4 319 9534 0)

## Technical data

General unit data	Kind of current	AC	
	Operating voltage and frequency	refer to «Type summary»	
	Drive motor	synchronous motor	
	Power consumption	20 VA	
	Angular rotation	adjustable between 0° and max. 160° (scale range)	
	Mounting position	optional	
	Degree of protection	IP 54 (provided knockout holes remain closed for mounting or are closed off, with adequate cable entries)	
	Cable entry	4 x Pg13.5 with thread 2 x Pg13.5 without thread	
	Direction of rotation	facing the gear train side: counterclockwise or clockwise (selectable), delivery: <b>counterclockwise</b>	
	Torque	refer to torque charts and drive shafts	
	Holding torque	max. torque	
	Running time	10...90 s (refer to «Type summary»)	
	End and auxiliary switches		
	- Type	to DIN 41636	
	- Switching voltage	AC 24...250 V	
	- Switching capacity	to CEE 24 / VDE 0630 7.5 (3) A, AC 250 V	
	Number of end switches	2	
	Number of auxiliary switches	max. 6	
	Drive shaft	exchangeable	
	Weight	approx. 3.3 kg	
	Environmental conditions	<b>Storage</b>	DIN EN 60 721-3-1
		Climatic conditions	class 1K2
		Mechanical conditions	class 1M2
Temperature range without integrated AGA56...		-50...+60 °C	
Humidity		< 95 % r.h.	
<b>Transport</b>		DIN EN 60 721-3-2	
Climatic conditions		class 2K2	
Mechanical conditions		class 2M2	
Temperature range without integrated AGA56...		-50...+60 °C	
Humidity		< 95 % r.h.	
<b>Operation</b>		DIN EN 60 721-3-3	
Climatic conditions		class 3K3	
Mechanical conditions		class 3M3	
Temperature range without integrated AGA56...		-20...+60 °C	
Humidity		< 95 % r.h.	



**Condensation, formation of ice and ingress of water are not permitted!**



## Torques

SQM50...

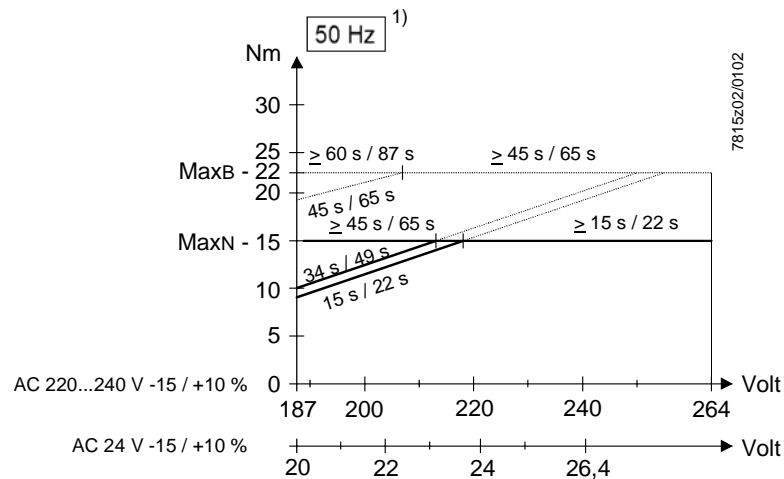

SQM53... / SQM54...

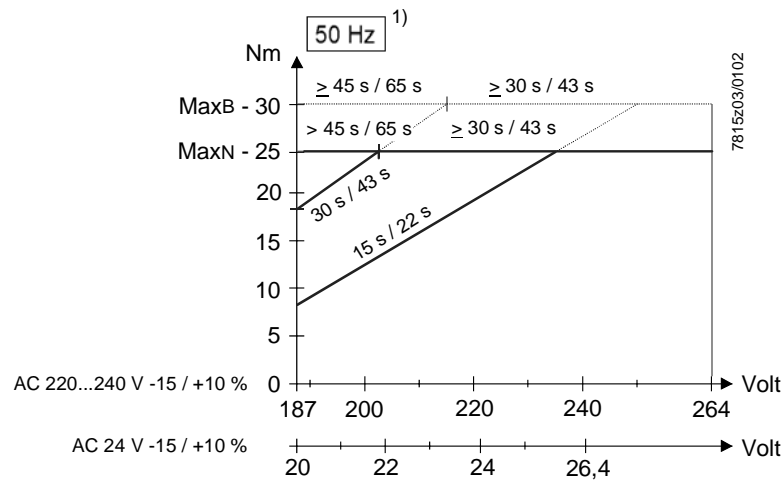

SQM56...

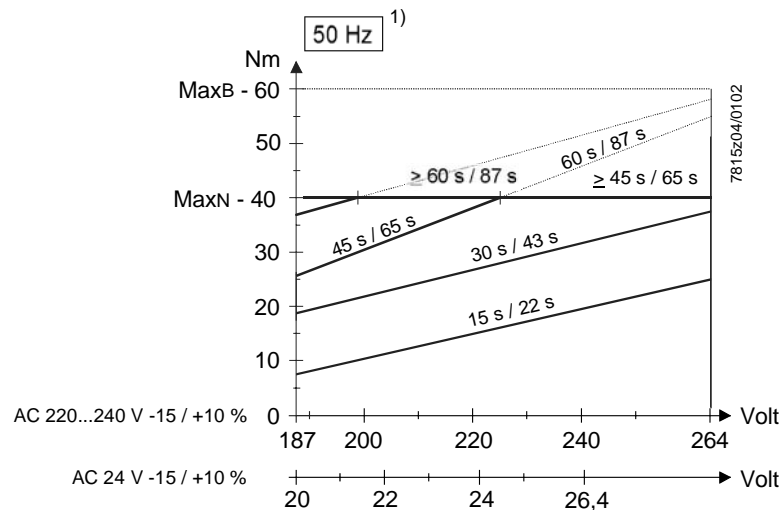

Legend

1) At 60 Hz frequency, running times are about 17 % shorter and torques are proportionally lower



Each drive side is capable of delivering the maximum torque, but the total torque of both sides must not exceed the maximum permissible torque of actuator.

With appropriate running time for 90° / 130°:

— Torque in continuous operation

----- Release or starting torque = short-time torque

MaxN Max. permissible torque in continuous operation for all running times

MaxB Max. permissible release or starting torque for all running times

**Connection terminals**

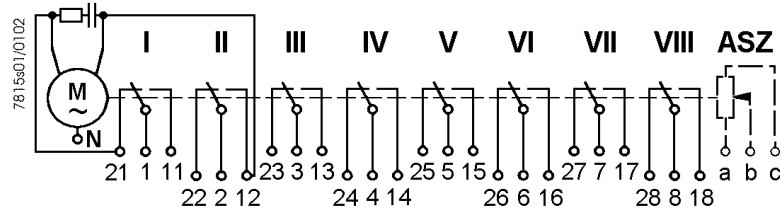
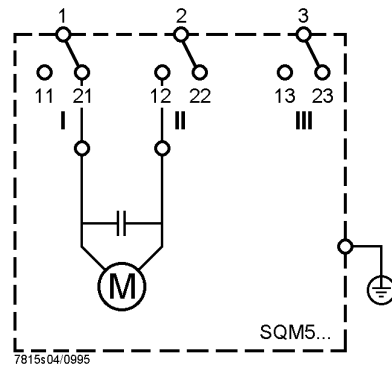

Diagram shows the maximum number of switches (2 end and 6 auxiliary switches). On versions with fewer than 6 auxiliary switches, the higher numbers are not used. For example, the actuator version with 2 end and 2 auxiliary switches does not use switches V, VI, VII and VIII.

**Direction of rotation**

By exchanging the 2 motor connecting cables, the actuator's direction of rotation can be changed from counterclockwise to clockwise.

Counterclockwise rotation



Clockwise rotation

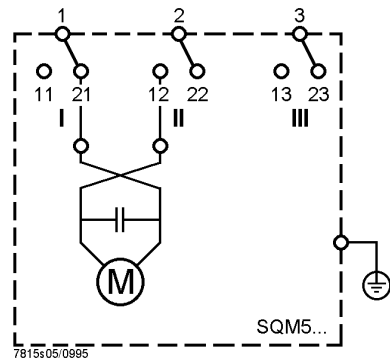

**Note**

When changing the direction of rotation from counterclockwise to clockwise, the cams must be readjusted.

Clockwise rotation: Red scales on the cam shaft, double arrow on the cams.

Counterclockwise rotation: Black scales on the cam shaft, single arrow on the cams.



Dimensions (cont'd)

Dimensions in mm

AGA57.1

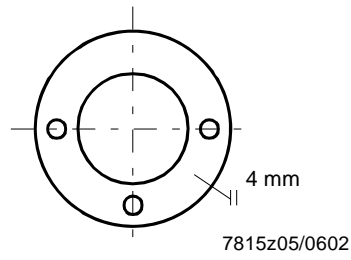

AGA57.2

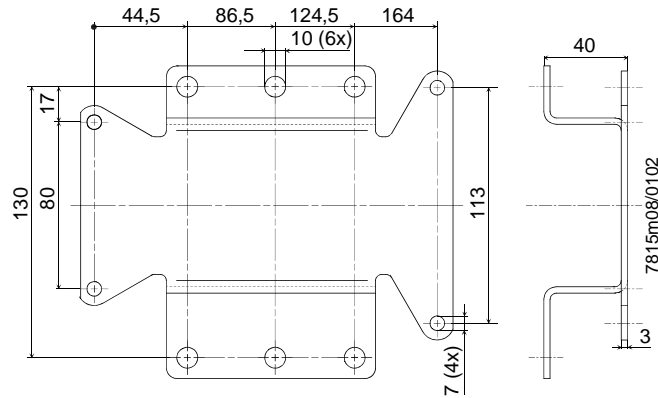

AGA57.3

