



## Actuators

for air dampers and control valves of oil burners

**SQM1...**  
**SQM2...**

### Reversible electromotoric actuators

- **Torques:**
  - SQM1... up to 10 Nm
  - SQM2... up to 20 Nm
- **Running times:**
  - SQM1... 14...100 s
  - SQM2... 29...66 s
- **Versions:**
  - Clockwise or counterclockwise rotation

The SQM... and this Data Sheet are intended for use by OEMs which integrate the actuators in their products!

### Use

The reversible actuators of the SQM... range are for use in connection with controllers or switching devices equipped with changeover contacts.

## Warning notes



To avoid injury to persons, damage to property or the environment, the following warning notes **must** be observed!

### Only qualified staff may open, interfere with or modify the actuators!

- All activities (mounting, installation and service work, etc.) must be performed by qualified staff
- Before making any wiring changes in the connection area of the units, completely isolate the equipment from mains supply (all-polar disconnection). If not observed, there is a risk of electric shock hazard
- Ensure protection against electric shock hazard by providing adequate protection for the connection terminals and by securing the housing cover
- Each time work has been carried out (mounting, installation, service work, etc.), check to ensure that wiring is in an orderly state
- Fall or shock can adversely affect the safety functions. Such units must not be put into operation, even if they do not exhibit any damage

## Mounting notes

- Ensure that the relevant national safety regulations are complied with
- When mounting actuator and damper linkage, the gear train can be disengaged with a lever, thus allowing the actuator's drive shaft to be easily adjusted in either direction of rotation

## Standards and certificates



Conformity to EEC directives  
 - Electromagnetic compatibility EMC (immunity)  
 - Low-voltage directive

2004/108/EC  
 2006/95/EC





ISO 9001: 2000  
 Cert. 00739



ISO 14001: 2004  
 Cert. 38233

In combination with the burner control

Type		
SQM10.15502	X	X
SQM10.15561	X	X
SQM10.15562	X	X
SQM10.16102	X	X
SQM10.16502	X	X
SQM10.16532 <sup>5)</sup>	X	X
SQM10.16561	X	X
SQM10.16562	X	X
SQM10.17502	X	X
SQM11.16502	---	X
SQM20.16502	---	X
SQM21.18501	---	X
SQM20.18502	---	X
SQM21.16502	---	X
SQM21.18502	---	X

## Disposal notes

---



The actuator contains electrical and electronic components and must not be disposed of together with household waste.  
Local and currently valid legislation must be observed.

## Mechanical design

---

Housing	<ul style="list-style-type: none"><li>- The actuator's cover is made of impact-proof and heat-resistant plastic. Color of cover: Dark-grey</li><li>- The housing of the gear train is made of die-cast aluminium and has 4 threaded holes for cable glands Pg11</li></ul>
Actuator	<ul style="list-style-type: none"><li>- Reversible, locking-proof synchronous motor</li></ul>
Adjustment of switching points	<ul style="list-style-type: none"><li>- With adjustable cams</li><li>- Setting scales beside the cams give the switching point's angular position</li><li>- Cams can be adjusted manually, either with the enclosed hook spanner or tool</li></ul>
Position indicator	<ul style="list-style-type: none"><li>- Internally: Scale at the beginning of the cam stack on the gear train side</li><li>- Only SQM21...: Equipped with position indicator visible from outside (also refer to «Dimensions»)</li></ul>
Electrical connections	<ul style="list-style-type: none"><li>- Screw terminals</li></ul>
Gear train	<ul style="list-style-type: none"><li>- The reduction gearing has self-lubricating sinter-bronze bearings and requires no maintenance</li></ul>
Drive shaft	<ul style="list-style-type: none"><li>- Ready fitted to the front of the gear train</li></ul>
Mounting and fixing	<ul style="list-style-type: none"><li>- Gear train front is used as the mounting surface</li><li>- Fixing by means of 3 threaded holes with inside thread M5</li></ul>

## Type summary

Running time 50 Hz <sup>1)</sup> for angular rotation		<sup>3)</sup>	Direction of rotation when facing the drive shaft and with control voltage applied to terminal 1	Number of auxiliary switches	Nominal torque <sup>2)</sup>	Start- ing torque	Hold- ing torque	AC 220...240 V <sup>4)</sup>	AC 110 V <sup>4)</sup>
90°	130°							Type reference	Type reference
<b>Standard version</b> , diameter of drive shaft 10 mm									
14 s	20 s	1	Counterclockwise	5	10 Nm	10 Nm	4 Nm	<b>SQM10.15502</b>	---
14 s	20 s	2	Counterclockwise	5	10 Nm	10 Nm	4 Nm	<b>SQM10.15562</b>	<b>SQM10.15561</b>
29 s	42 s	1	Counterclockwise	1	10 Nm	15 Nm	7 Nm	<b>SQM10.16102</b>	---
29 s	42 s	1	Counterclockwise	5	10 Nm	15 Nm	7 Nm	<b>SQM10.16502</b>	---
29 s	42 s	1	Counterclockwise	5	10 Nm	15 Nm	7 Nm	<b>SQM10.16532</b> <sup>5)</sup>	---
29 s	42 s	2	Counterclockwise	5	10 Nm	15 Nm	7 Nm	<b>SQM10.16562</b>	<b>SQM10.16561</b>
70 s	100 s	1	Counterclockwise	5	10 Nm	15 Nm	15 Nm	<b>SQM10.17502</b>	---
<b>Heavy duty version</b> Diameter of drive shaft 12 mm Gear train shafts made of hardened steel, gearwheels nitrated Type SQM21... with external position indication (refer to «Dimensions»)									
29 s	42 s	1	Counterclockwise	5	20 Nm	20 Nm	12 Nm	<b>SQM20.16502</b>	---
45 s	66 s	1	Counterclockwise	5	20 Nm	20 Nm	12 Nm	<b>SQM20.18502</b>	---
29 s	42 s	1	Clockwise	5	20 Nm	20 Nm	12 Nm	<b>SQM21.16502</b>	---
45 s	66 s	1	Clockwise	5	20 Nm	20 Nm	12 Nm	<b>SQM21.18502</b>	<b>SQM21.18501</b>

1) At frequency 60 Hz, running times are about 17 % shorter

2) Based on 150,000 position changes

3) Wiring according to diagram no.

4) Additional types on request

5) With thread for mounting an ASK33.9

## Ordering

When ordering, please give type references of actuator and accessories according to «Type summary».

In addition to the actuator, the following item is to be ordered separately; it is also supplied separately:

~~Changeover relay ASZ50.5~~

## Accessories

### Assembly set

**ASK33.9**

- For mounting on a butterfly valve VKF41...C
- Refer to Mounting Instructions M7815.4 (4 319 9535 0)
- Only for SQM1...

### ~~Changeover relay~~

**ASZ50.5**

~~For single wire control of SQM10... / SQM20...~~

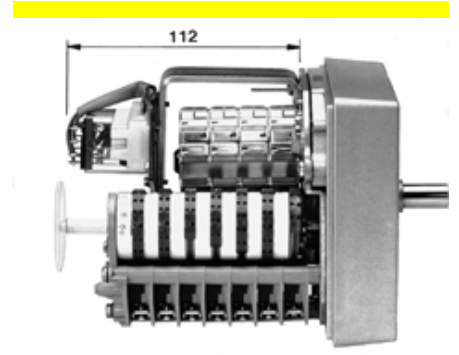
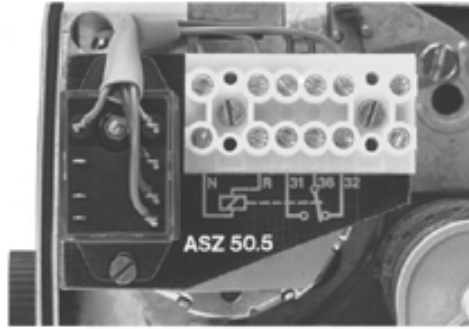

Potentiometer ASZ...  
For self-mounting

Refer to Data Sheet N7924

## Technical data

General actuator data	Operation voltage	AC 220...240V, 50 Hz –15 % / +10 % AC 220 V, 60 Hz –15 % / +10 %	
		On request: AC 110 V, 50 / 60 Hz ±6 %	
	Switching capacity of end and auxiliary switches	10 (3) A, AC 24...250 V	
	Positioning angle	up to 160° (scale range)	
	Mounting position	optional	
	Safety class	I	
	Degree of protection	IP 54, DIN 40050 (at provided design of cable entry or fastening element for not used holes)	
	Cable entry M16 and M20	for 2 x M16 x 1.5 and 2 x M20 x 1.5	
	Weight	approx. 1.7 kg	
	Actuator motor	synchronous motor	
	Power consumption	9 VA	
	Environmental conditions	<b>Storage</b>	DIN EN 60 721-3-1
		Climatic conditions	class 1K3
Mechanical conditions		class 1M2	
Temperature range		-20...+70 °C	
Humidity		< 95 % r.F.	
<b>Transport</b>		DIN EN 60 721-3-2	
Climatic conditions		class 2K2	
Mechanical conditions		class 2M2	
Temperature range		-50...+60 °C	
Humidity		< 95 % r.h.	
<b>Operation</b>		DIN EN 60 721-3-3	
Climatic conditions		class 3K5	
Mechanical conditions	class 3M2		
Temperature range (switch on ratio < 0.5)	-20...+60 °C		
Humidity	< 95 % r.h.		



**Condensation, formation of ice and ingress of water are not permitted!**

## Function

The synchronous motor drives the shaft via the gear train. Attached to the drive shaft is a cam stack which actuates the end and auxiliary switches. The switching position of each end and auxiliary switch can be adjusted within the operating range with the help of the relevant cams.

The control section includes 2 end switches and a maximum of 5 auxiliary switches. In addition, a potentiometer can be integrated (as a feedback potentiometer for P-control, or as a setting unit for slave control, or for remote position indication).

**Connection diagram**

SQM...

Diagram no. 1 (H 4 318 1521 0)

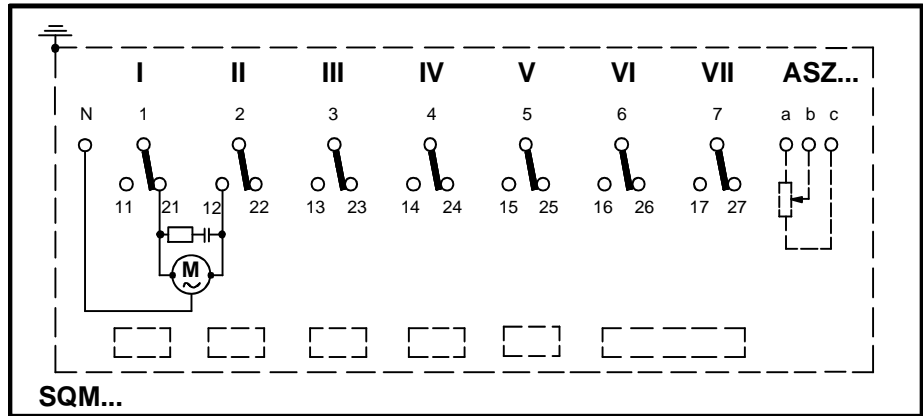

7812a01/1097

Diagram no. 2 (H 4 318 1522 0)

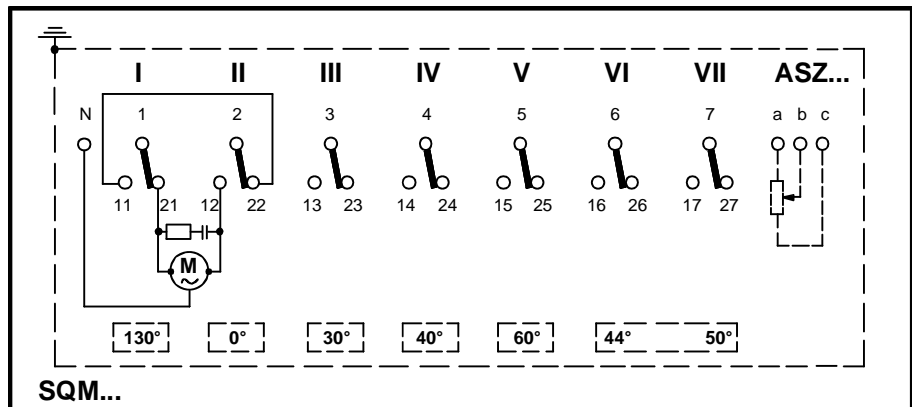

7812a02/1097

**ASZ50.5**

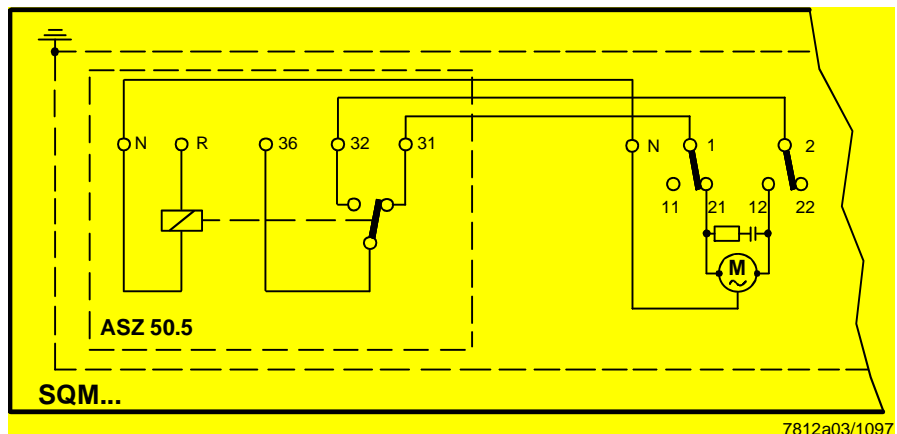

7812a03/1097

## Dimensions

Dimensions in mm

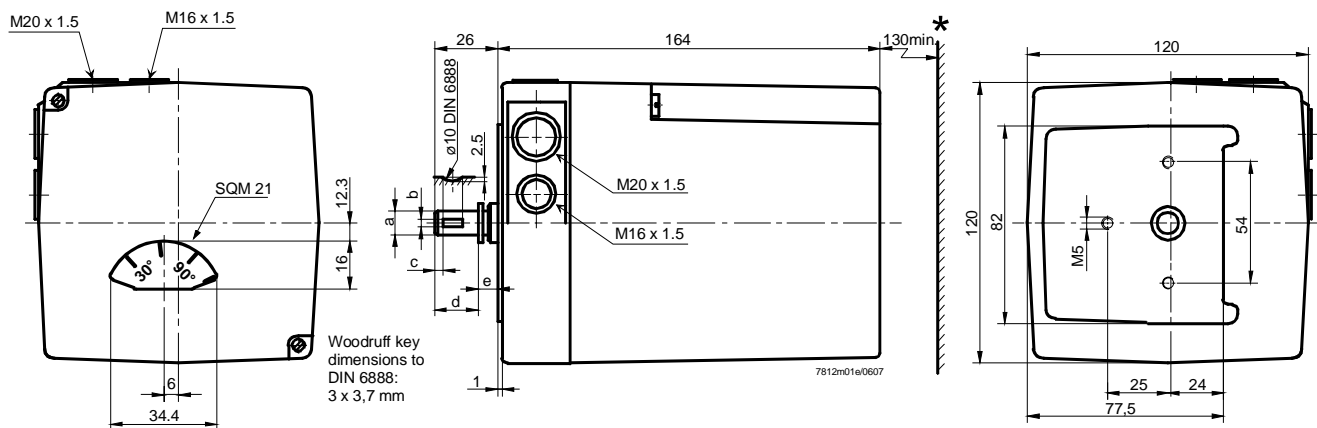

\* For remove the cover required distance to walls, devices of burners etc

Dimension table

Type reference	a	b	c	d	e
<b>SQM1...</b>	10h8	3 <sup>N9</sup>	4	20	6
<b>SQM2...</b>	12h8	3 <sup>N9</sup>	4	21.5	4.5

The groove on the drive shaft is in the marked position, when the cam stack of control unit is in the 0° position (as supplied).